

## Technical Data Sheet



Kuerzi Avionics AG  
Flugplatz  
CH-9506 Lommis

info@kuerzi.com  
www.kuerzi.com

Tel. +41 52 376 22 27

### Description

The KME130 EMS BATTERY provides battery power if no other aircraft power is available. A single connector minimises and simplifies system connections. The KME130 has an operating range of +18VDC to +32VDC. When +28VDC input power is supplied to the KME130 the output is connected to the input (feedthrough) and the KME130 battery cells are recharged. The voltage, current and temperature of the charging cycle is constantly monitored.

During discharge the battery cells are protected against low voltages and high currents. After detecting a low voltage condition the KME130 is reset only when input power becomes available.

The KME130 meets aviation standards and requirements and is delivered with an EASA Form 1. The applicable approval can be provided by us specifically for your aircraft type.

### Features

- +24VDC / 2.4Ah
- Wide operating range from +18VDC to +32VDC
- 5A polyfuse

### Application example

The KME130 provides backup battery power for our EMS system on a number of different platforms. The KME130 can also be installed as a standalone battery for your avionics system on your rotorcraft or aircraft.

On your request the KME130 can be altered or adapted to your requirements.

## Environmental Specifications according DO-160 / ED-14

Temperature and Altitude	DO-160G Section 4.0 Cat. B1
Temperature Variation	DO-160G Section 5.0 Cat B
Operational Shock and Crash Safety	DO-160G Section 7.0 Cat. E
Vibration	DO-160G Section 8.0 Cat. U2
Magnetic Effect	DO160G Section 15.0 Cat. Z
Power Input	DO160G Section 16.0 Cat. Z
Emission of Radio Frequency Energy	DO-160G Section 21.0 Cat. M

## Interface

Connector	Pin	PIN Functions	PIN Class	Current	Description
J1	A	28VDC PWR	INPUT	2.4A (7.5A)*	CHARGING INPUT
J1	B	28VDC PWR RETURN	INPUT	2.4A (7.5A)	CHARGING INPUT
J1	C	24VDC PWR	OUTPUT	5A	BATTERY OUTPUT**
J1	D	24VDC PWR RETURN	OUTPUT	5A	BATTERY OUTPUT
J1	E	NC	-	-	RESERVED
J1	F	NC	-	-	RESERVED

\* MAXIMUM CHARGING CURRENT (MAXIMUM CHARGING CURRENT & FEEDTHROUGH CURRENT)

\*\* BATTERY 24VDC INTERNALLY LIMITED BY PTC (28VDC FEEDTHROUGH)

## Mechanical Dimensions

Weight of the unit 1.66 Kg

Weight of the unit including required installation materials (w/o wiring) 1.68 Kg

All dimensions [mm]

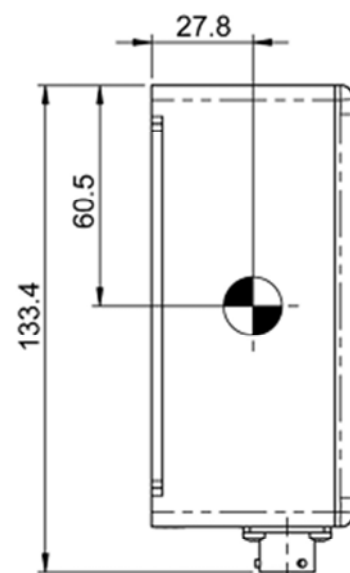
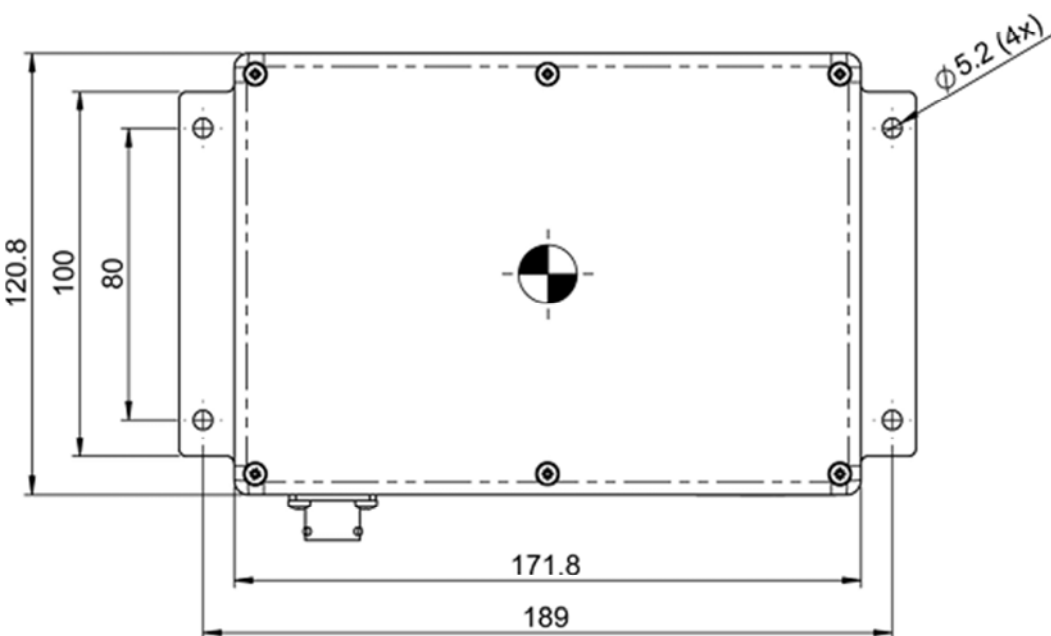
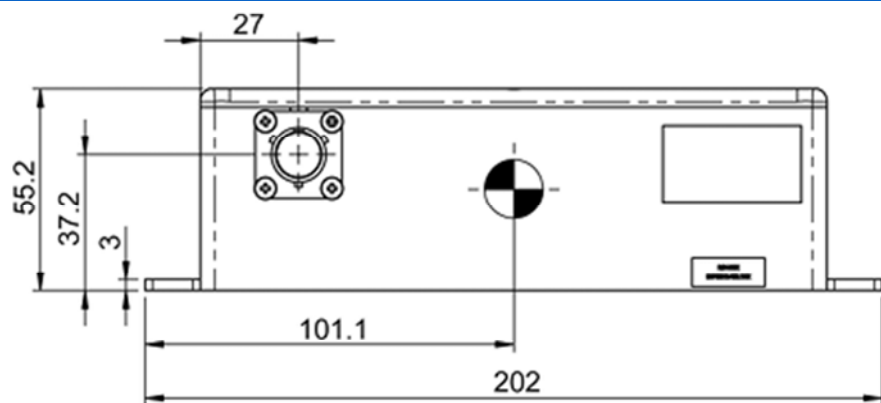

### Configuration / Ordering Data

Part Number	Type	Description
1034278.6	KME130	+24VDC/2.4Ah EMS battery

#### Additional Parts for installation:

Qty	Part Number	Description
1	PT06SE10-6P(SR)	STRAIGHT PLUG, PIN, 6POL, CRIMP, STRAIN RELIEF